

## LE152-1-M12

### Material

PPA - Polyphthalamide  
(PA hex nut)



**How it works** Movement of the magnetic float opens/closes a hermetically sealed contact ([reed switch](#)).

- Details**
- 150mm length;
  - On/Off SPST output;
  - Work as normally open or normally closed, by inverting float position;
  - M12 output connection.

- Typical applications**
- Tank liquid level control in 2 points;
  - Pumps automation;
  - Machine tools.



**Chemical products** require preliminary tests to confirm compatibility.

**Liquid with ferrous particles** should be avoided.

### Technical specifications

Maximum operating pressure	<b>2bar</b>
Operating temperature range	<b>-10°C to 90°C</b>
Liquid minimum density (SG)	<b>0.70</b>
Sealing	<b>NBR gasket</b>
Output connection	<b>M12 male plug (4 pins)</b> <b>M12 female connector NOT included</b>
Enclosure rating	<b>IP66</b>
Electrical contact	<b>Reed Switch 20W/VA</b>

The sensors work in all voltage and current ranges displayed in the table below:

Operating Voltage	Max. Switching Power	Max. Switching Current	Peak Current
110Vac	20VA	0.2A	0.5A @20ms
220Vac	20VA	0.1A	0.5A @20ms
5Vdc	2.5W	0.5A	1A @20ms
12Vdc	5W	0.5A	1A @20ms
24Vdc	10W	0.5A	1A @20ms

**24Vac:** NOT recommended

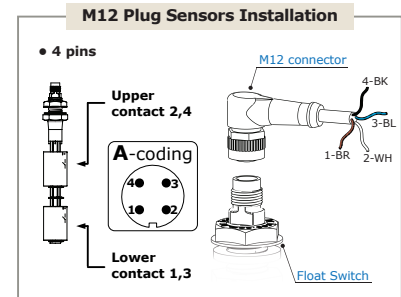

### Important!

- For cables longer than 20 meters.
- Relay coupler, timing relay, frequency inverter.

A series **resistor** must be installed.  
[Click and check how to install.](#)

### Dimensions (mm) and Weight

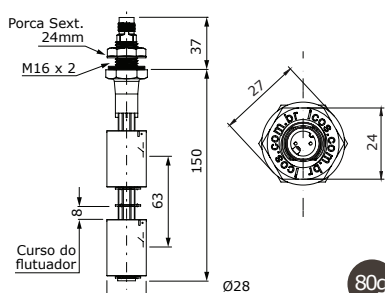

### Mounting

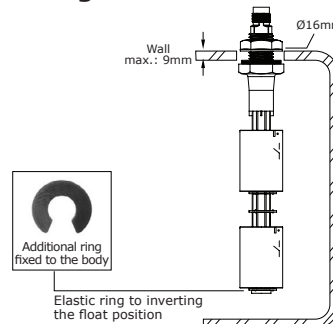

### Typical connection to contactor

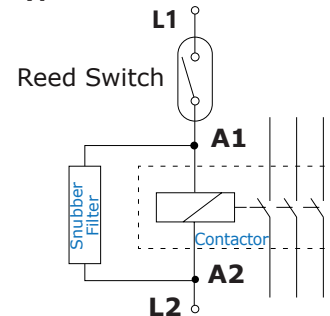

level sensor | level switch | float level | float switch | magnetic level switch | liquid level controller

[Click and Check:](#)

[Models and Prices](#) | [Datasheets](#) | [Operation Videos](#)

Flow Switches and Level Switches for liquids

Make it easy